



Medical In Space

Almog Zeron



SpacePharma



Hardware for startup

Bridging the gap between
hardware & firmware



With over 10 years of experience building and guiding teams through challenging hardware projects.

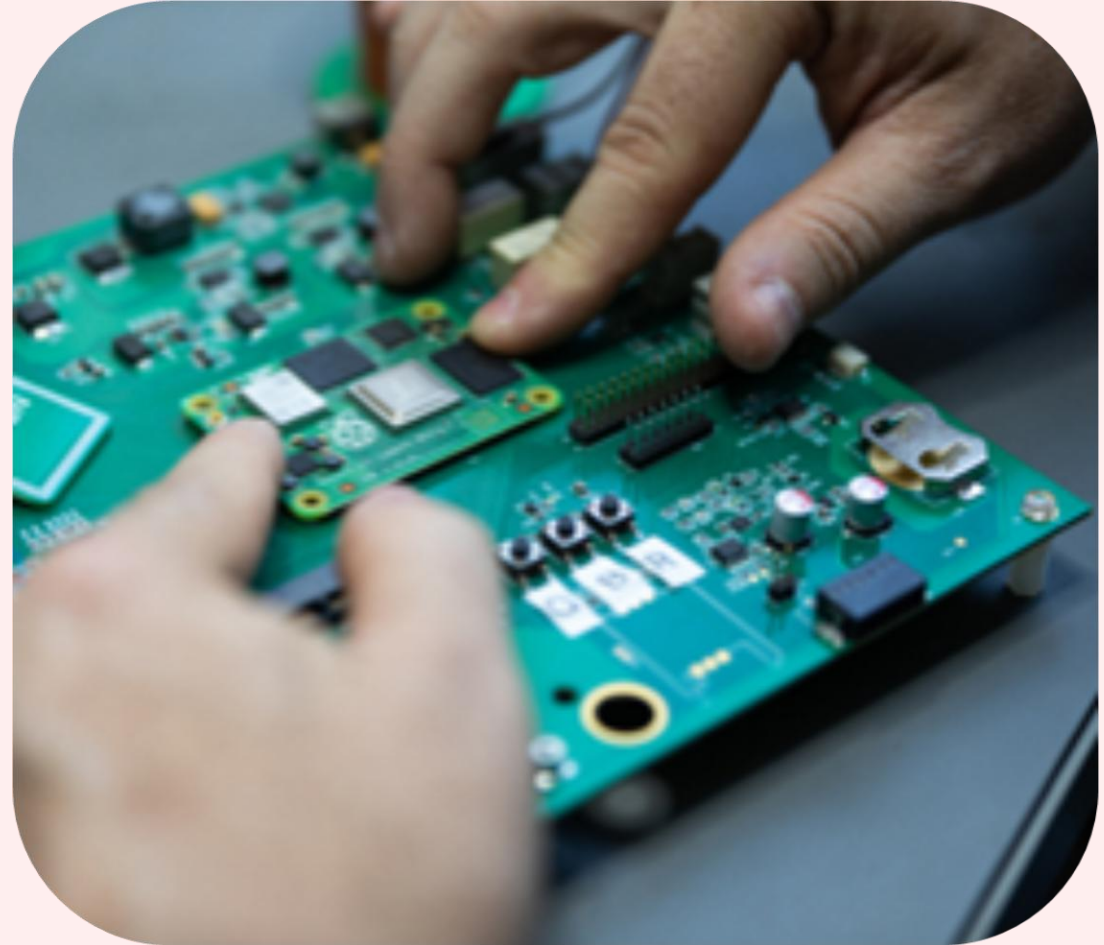

Industries We Empower

Agriculture

Vertical Farming



Zeron

Space

Autonomous Systems

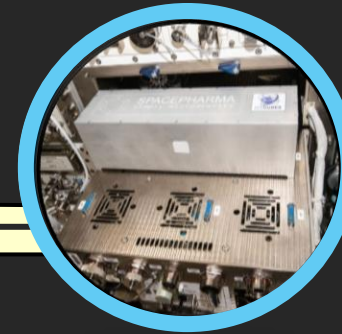

Medical

Life-Saving Device
& Neuroimaging

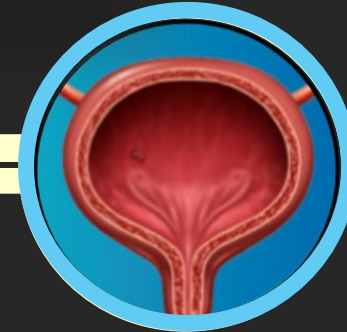

Commodity

Consumer Elec.
& Vending



Defense

Robotics & Drones



A high-angle, wide-field view from space. The Earth's horizon is a bright, glowing blue arc that curves across the middle of the frame. Below the horizon, the Earth's surface is visible, showing a mix of blue oceans and white, swirling clouds. In the foreground, the metallic, grid-like structure of a satellite or space station is visible, extending from the bottom left towards the center. The background is the deep black of space, filled with numerous small, distant stars.

Space

Evolution of Electronics in Space



Custom 'Rad-Hard' Hardware



Commercial Off-The-Shelf (COTS)
& Software Redundancy



Market Leader 2025

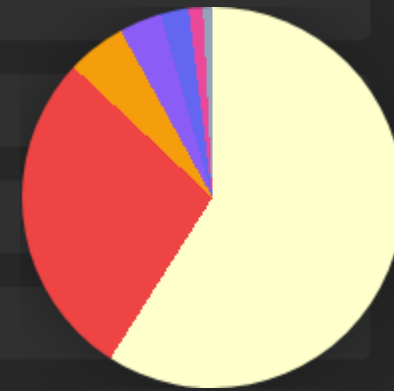
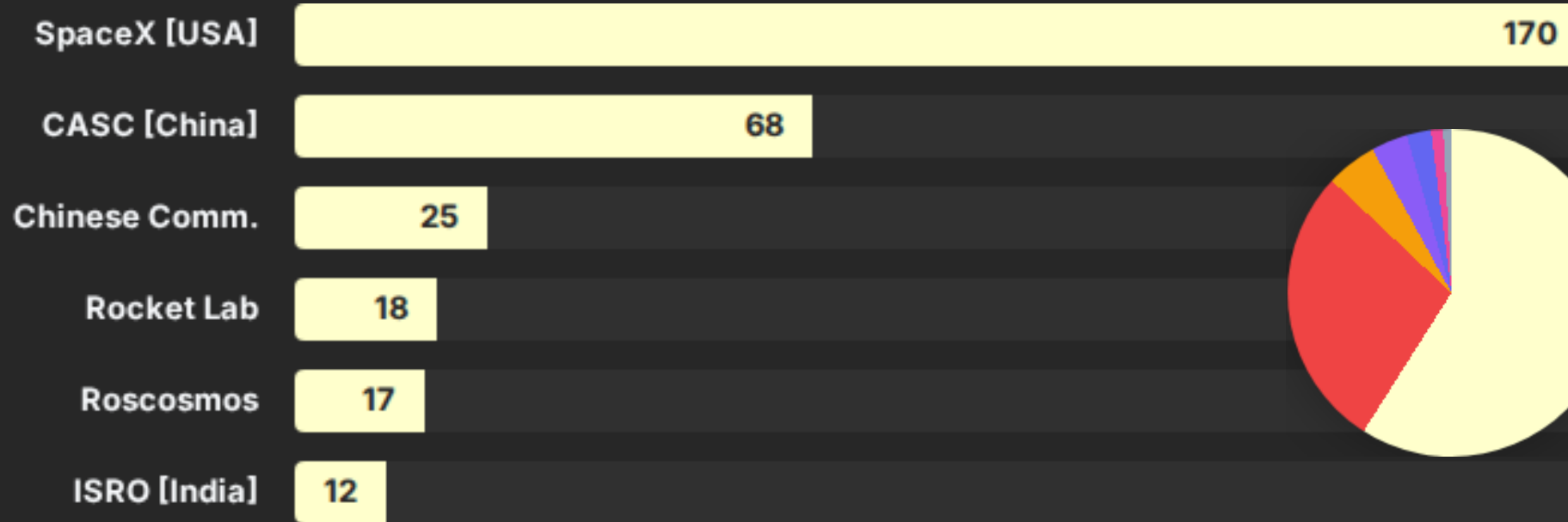

USA (59%)
CHINA (28%)
RUSSIA (5%)
INDIA (3.6%)
EUROPE (2.4%)
JAPAN (1.2%)

97.0%
Global Success

331
Total Attempts



SPACEX: Deployments

65%

Starlink - Internal
infrastructure growth.

15%

Commercial - Heavy
Satcom delivery.

16%

Defense - Classified
National Assets.

4%

ISS - Critical NASA
Support.

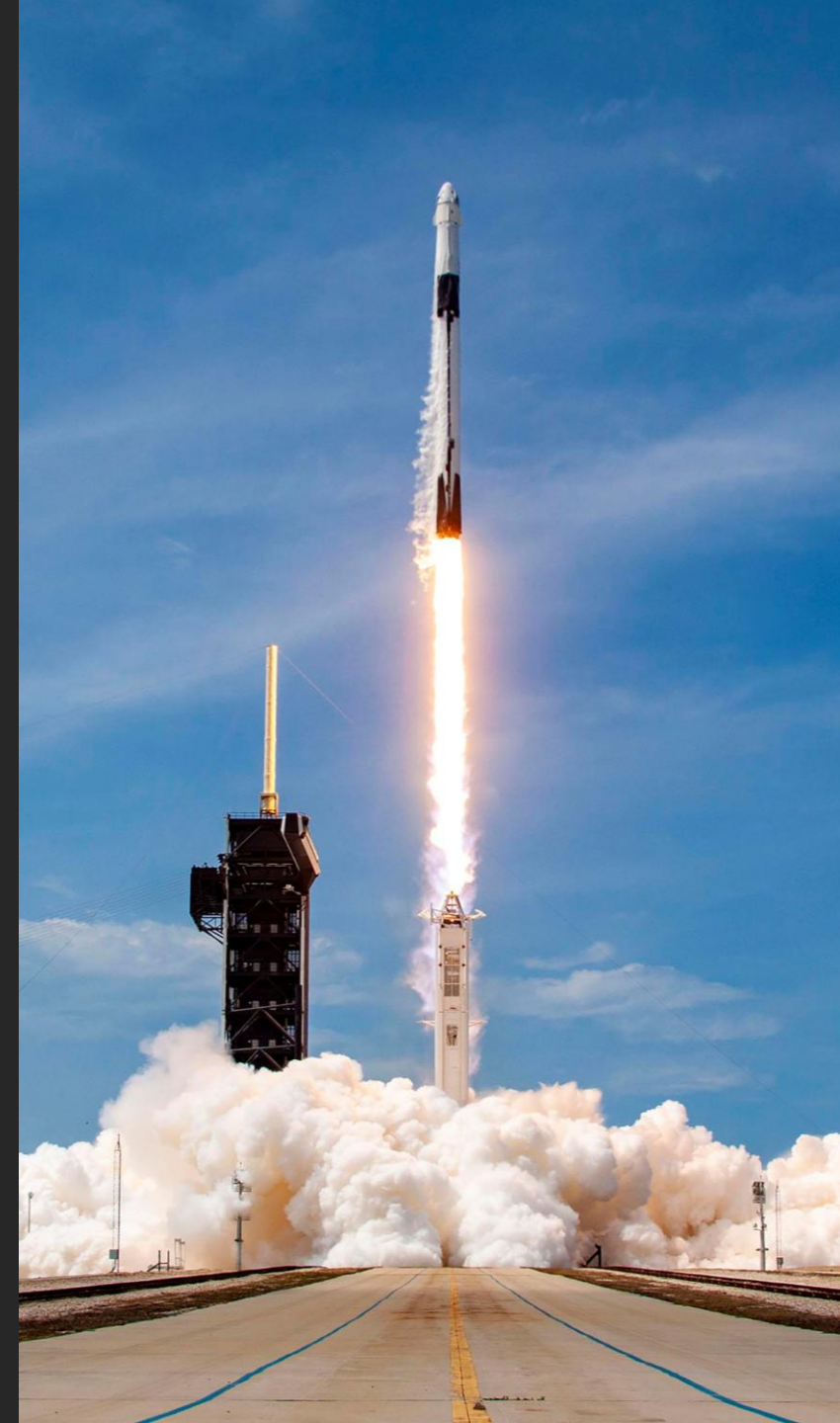

The New Generation:



Additional Key Players to Our Story



International Space Station
(United States, Russia, Europe,
Canada, Japan)

Research

- Operation from 2000 for space-based research
- Based on an expanded **Russian station**
- **Chinese station** also operates in space
- Continuous crew: **6–7 people**
- Post-Columbia: crews flew on **Soyuz**
- **Dragon** took over at the start of the **Ukraine war**
- **Dismantling in 2030 – Future Commercial station**

Additional Key Players to Our Story

Production

- Manufacturer: ESA – European Space Agency
- Autonomous system for low-Earth-orbit experiments
- First spacecraft capable of runway landing
- Based on a French–Italian platform by Thales Alenia Space
- Development started in 2019



Europe's first reusable space transportation system

SPAD as Inspiration





Autonomous Lab in space

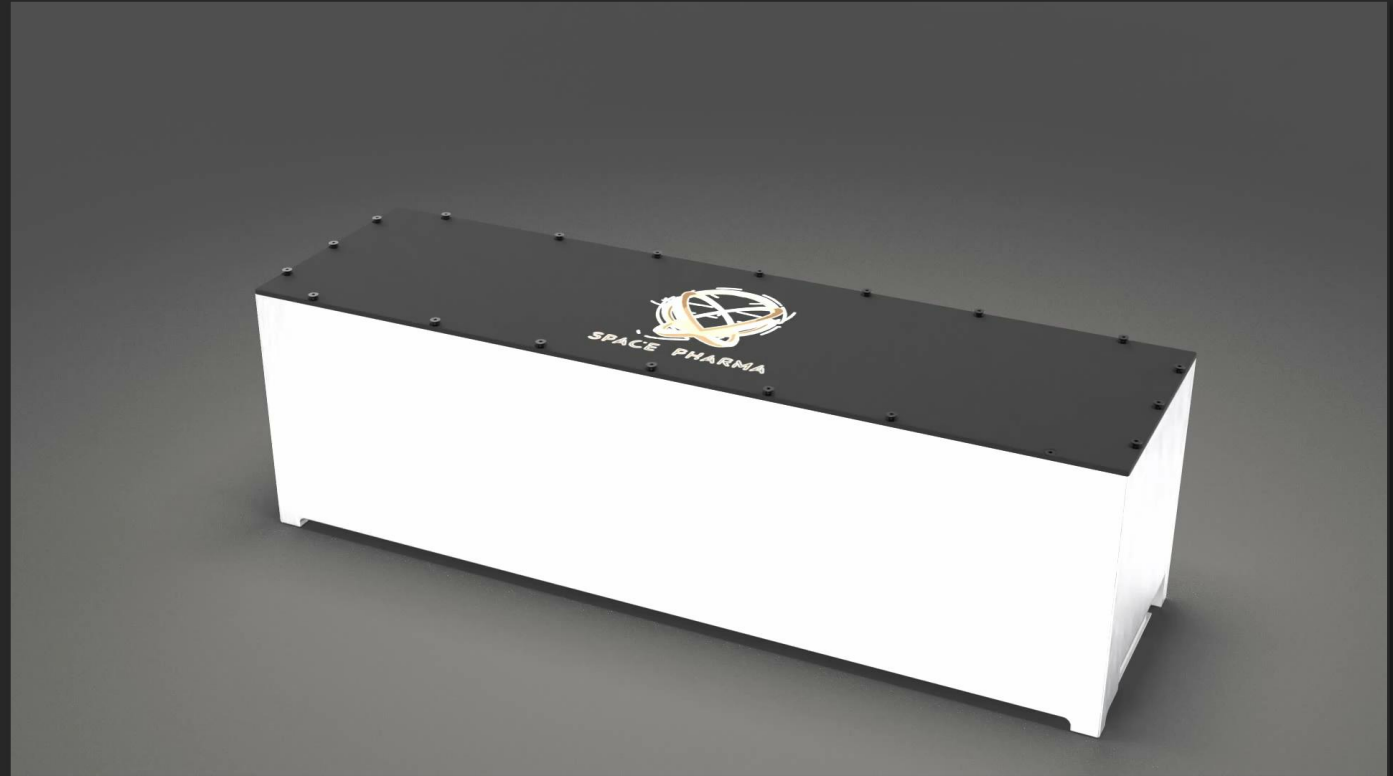
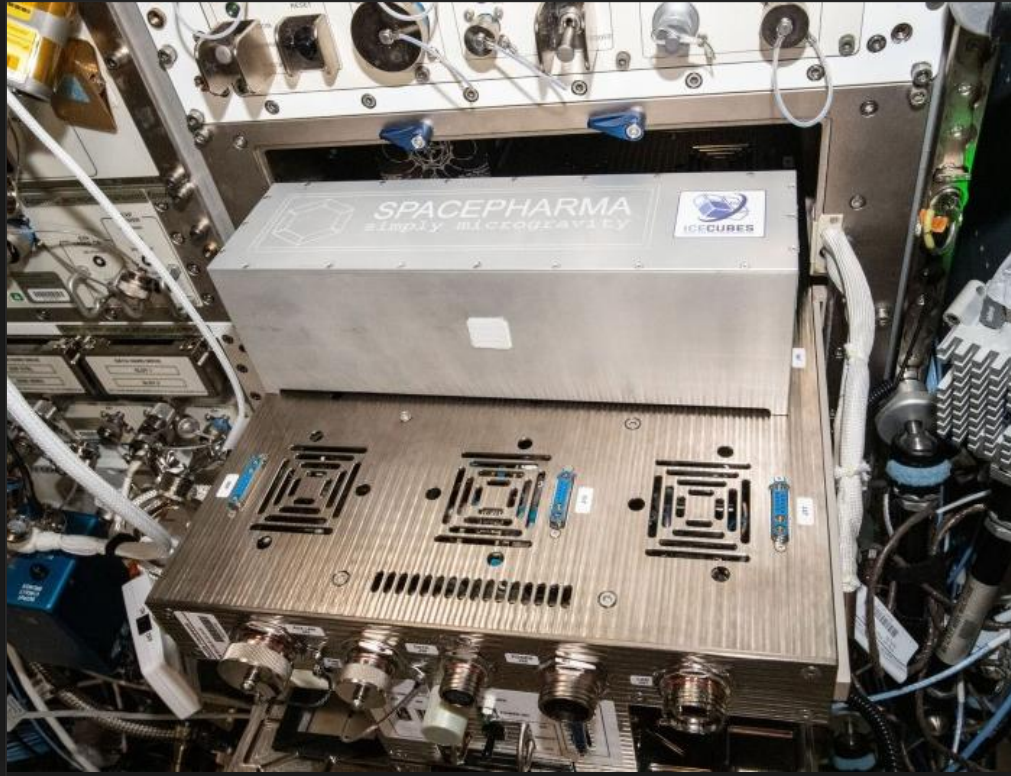



Autonomous Lab in space

Pumps

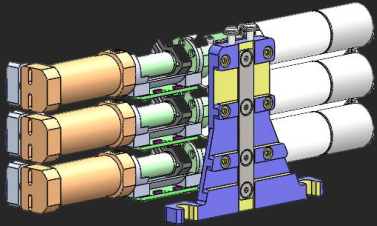

Fridge and Service Unit

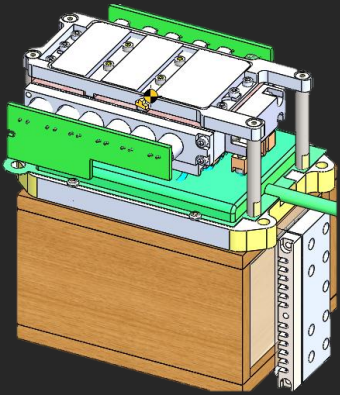

Computer-RP-CM4

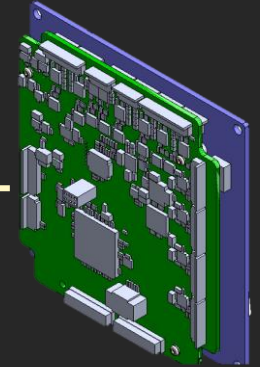

Microscope

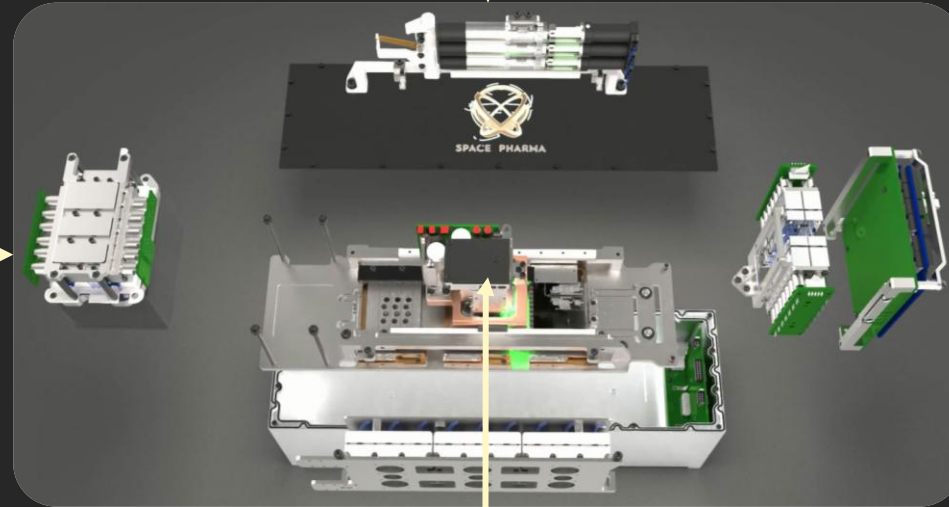
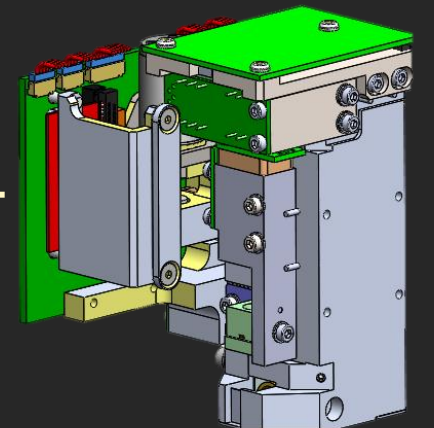



Lab on a Chip

- 3 chips per mission
- Full control:
 - Temperature
 - Flow rates
 - Volumes
- Tailored made

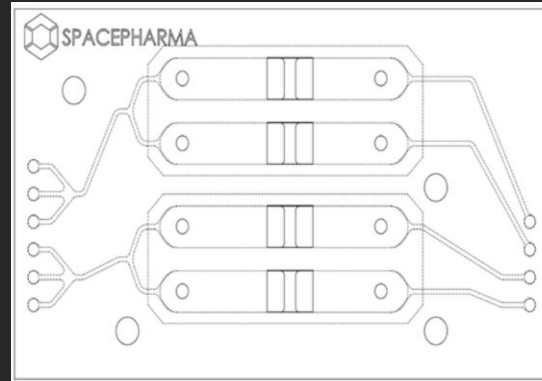

Wound Healing

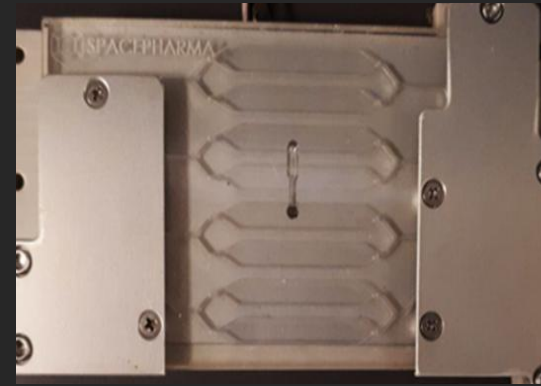
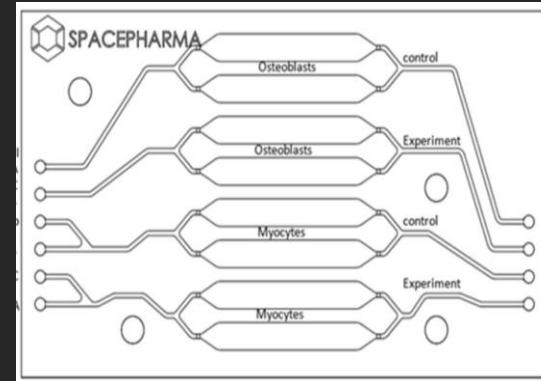

Bone Density Loss

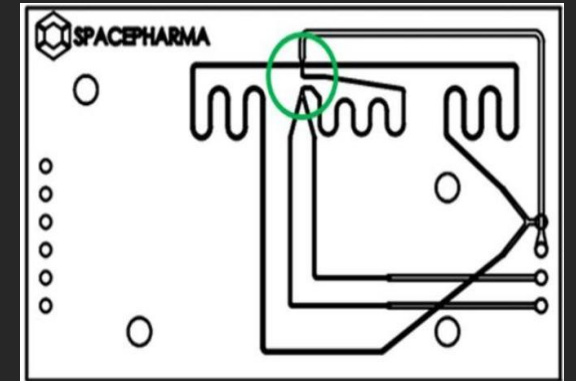

Crystallization in Droplets



I promised Medical In space

SPAD successfully produced Anti-body in zero gravity – they call it a Crystall

Earth

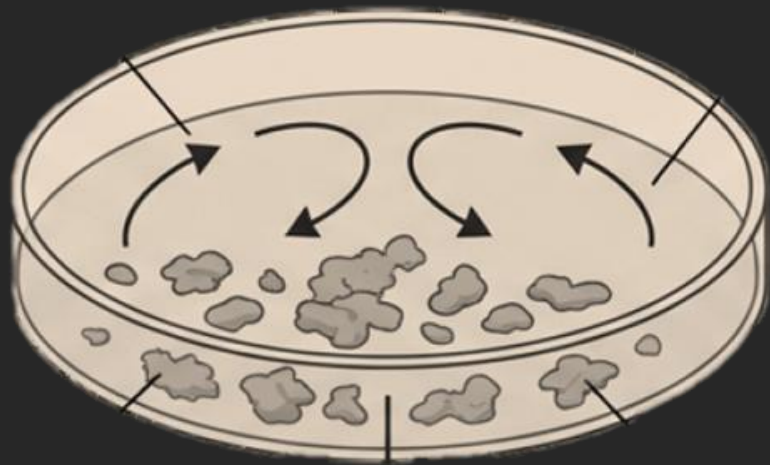

Gravity causes sedimentation and Natural convection currents.

Result:

Imperfect and smaller crystals,
Limit's drugs efficiency.

Space

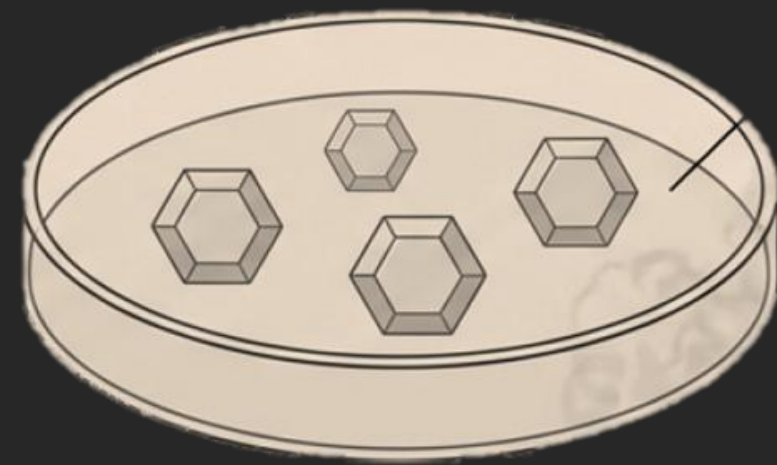

In microgravity, crystals grow in a **perfect 3D** —
larger, purer, and more effective.

The potential:

Discovering new drug–protein interactions





I promised Medical In space

SPAD successfully produced Anti-body in zero gravity – they call it a Crystall

Earth

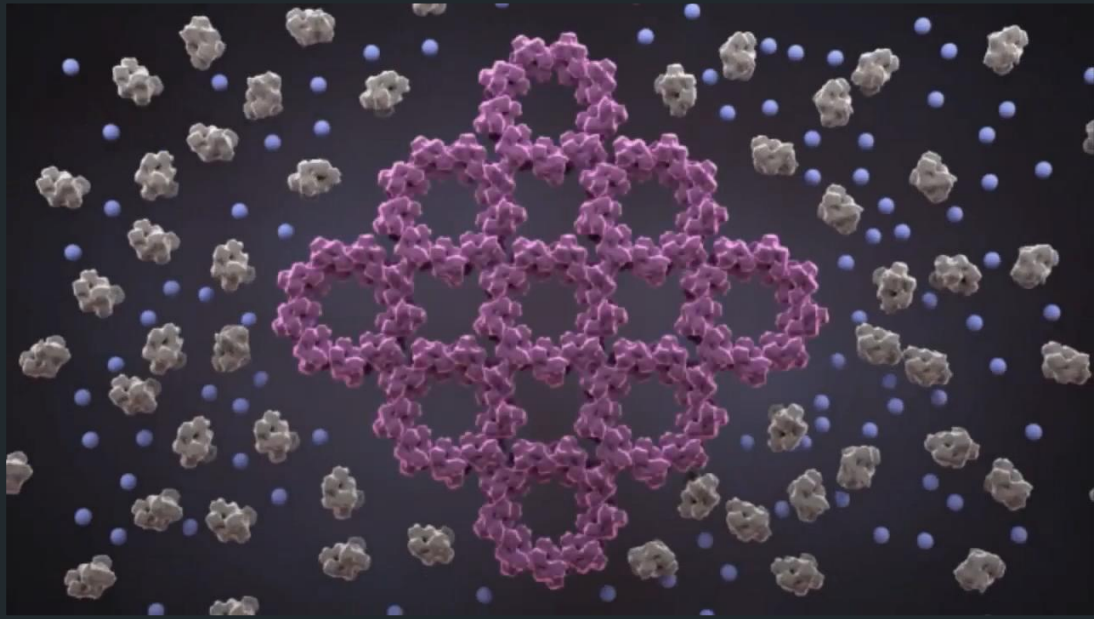

Space

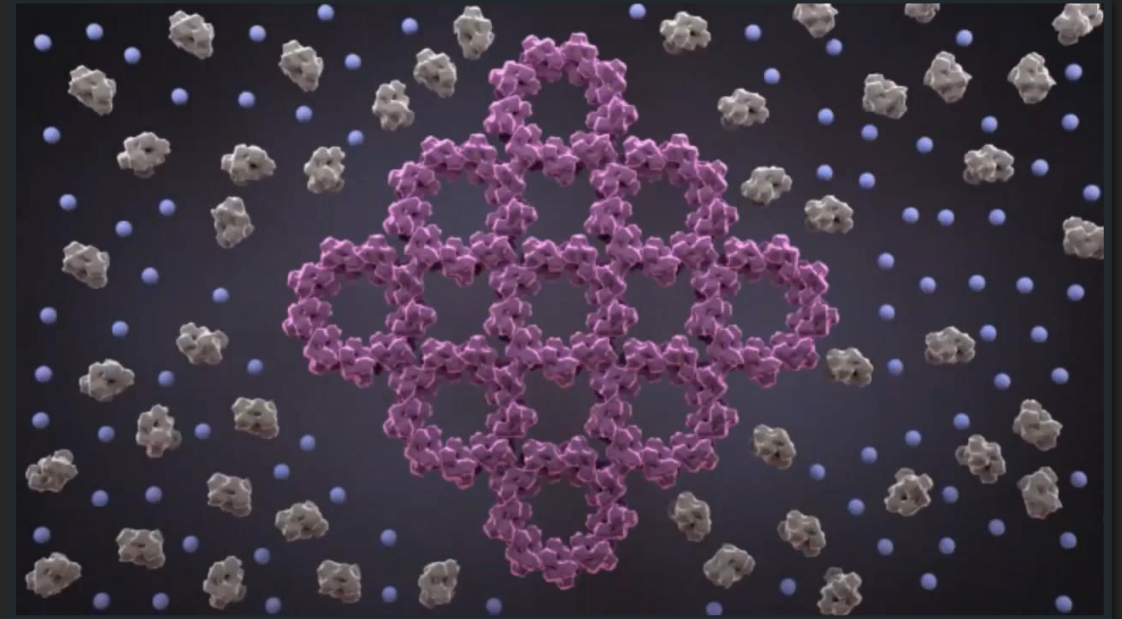



Would you like to see how it looks

SPAD successfully produced Anti-body in zero gravity – they call it a Crystal

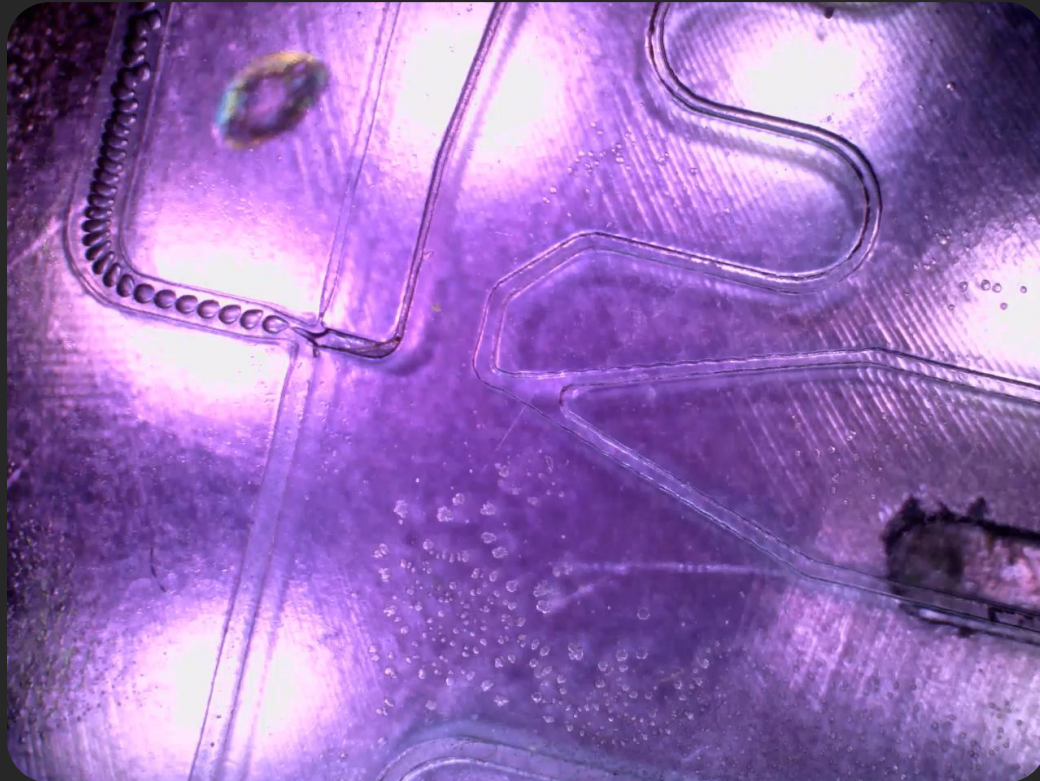

Challenges & Solutions



Strict Timelines

Challenge:

When the missile launches – project is over

Solution:

Short sprints, develop stability over new futures

Communication

Challenge:

Connection Hik-ups, Latency & reliability

Solution:

Off-line architecture

Dedicated Ethernet for Space

Launch Vibrations

Challenge:

A highly aggressive exit from the atmosphere that stresses the hardware.

Solution:

Reinforced connectors, redundancy, and using industrial-grade hardware wherever possible.

Radiation & Thermal

Challenge:

Data corruption & system failure

Solution:

Redundancy & CPU with proven space experience



Spactory



First drug factory in
microgravity.

Designed to be launched
on the Space Rider



The Process of Production

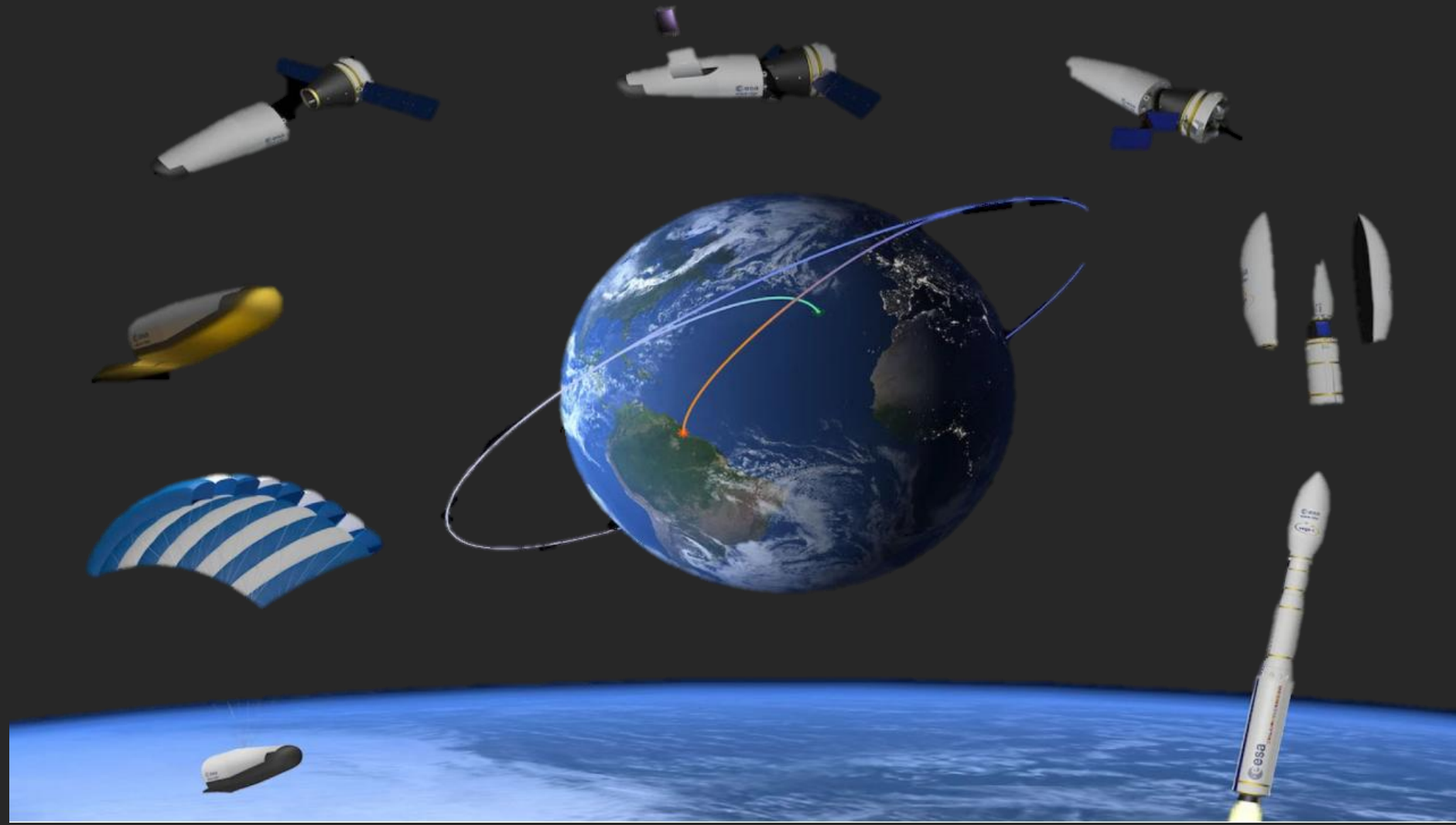

The Spactory:



8x Process Cartridges –
12KG Final product – over
100K drugs

OBC & Power
Management

The Cartridge:

Docking Station
Space Rider

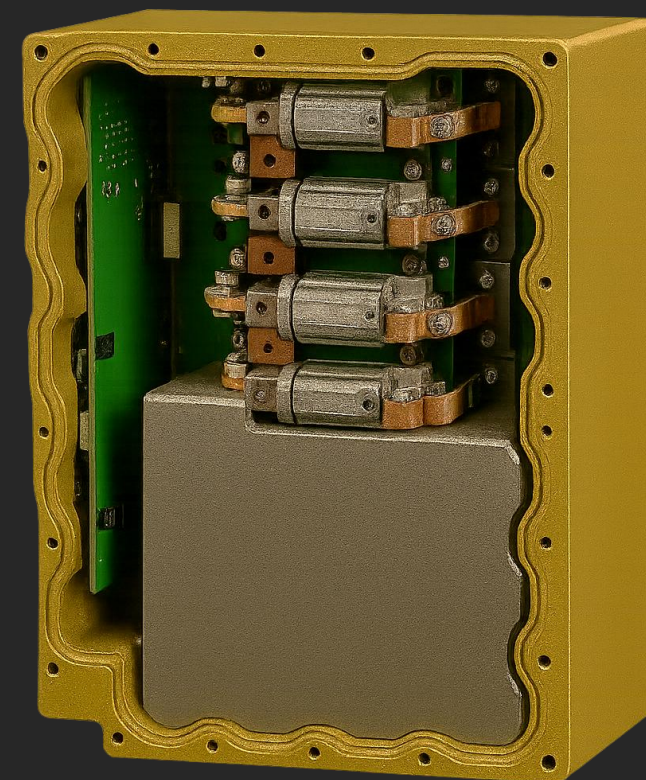
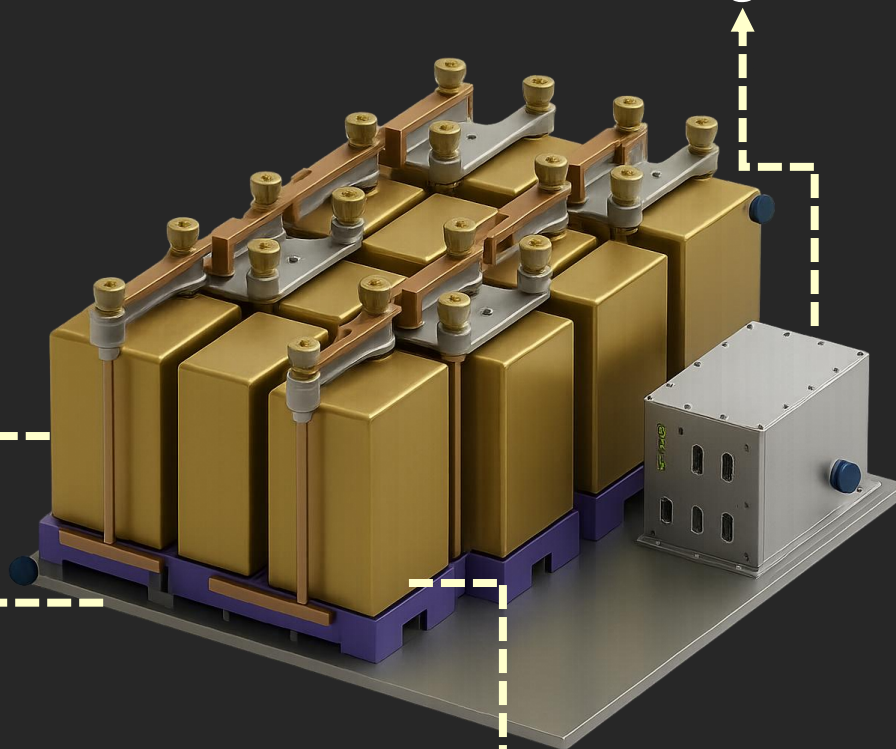



Inside the Spactory:

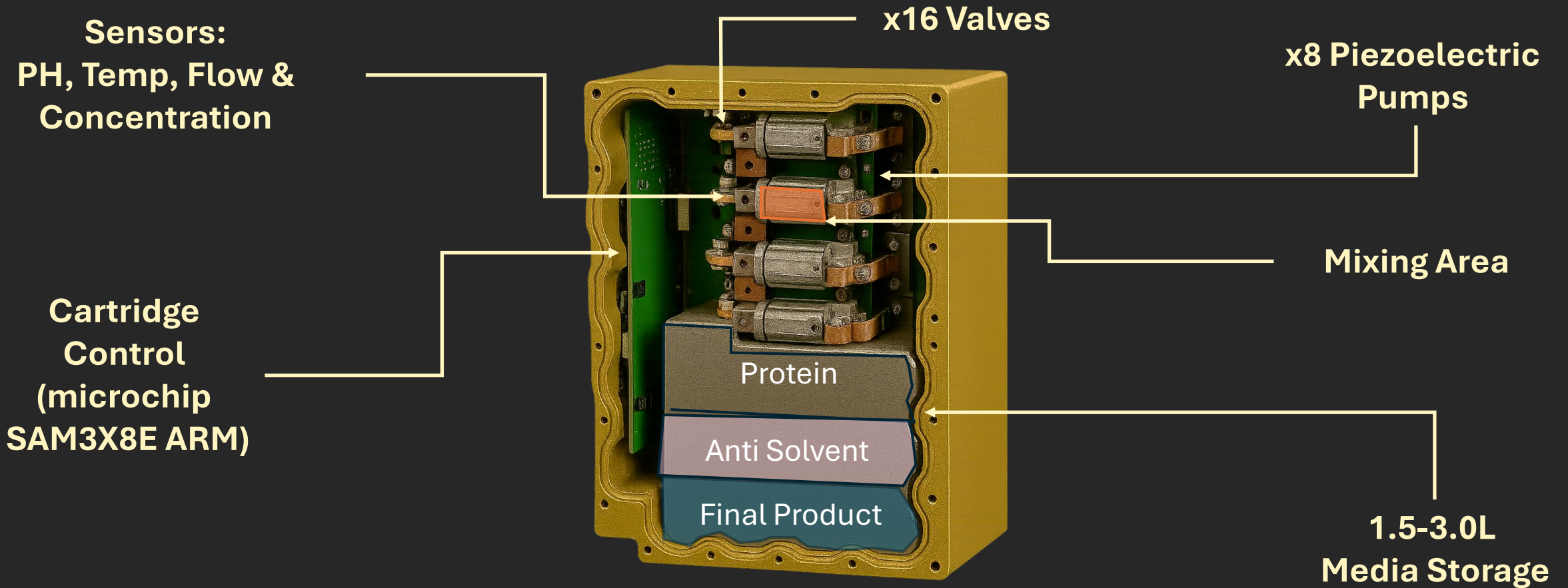

Communication: SpaceWire, RS422 & Ethernet, RS485, I2C, SPI, CANBUS





Development Status

Test-bed - Completed

Electronics - Production

Firmware - In progress

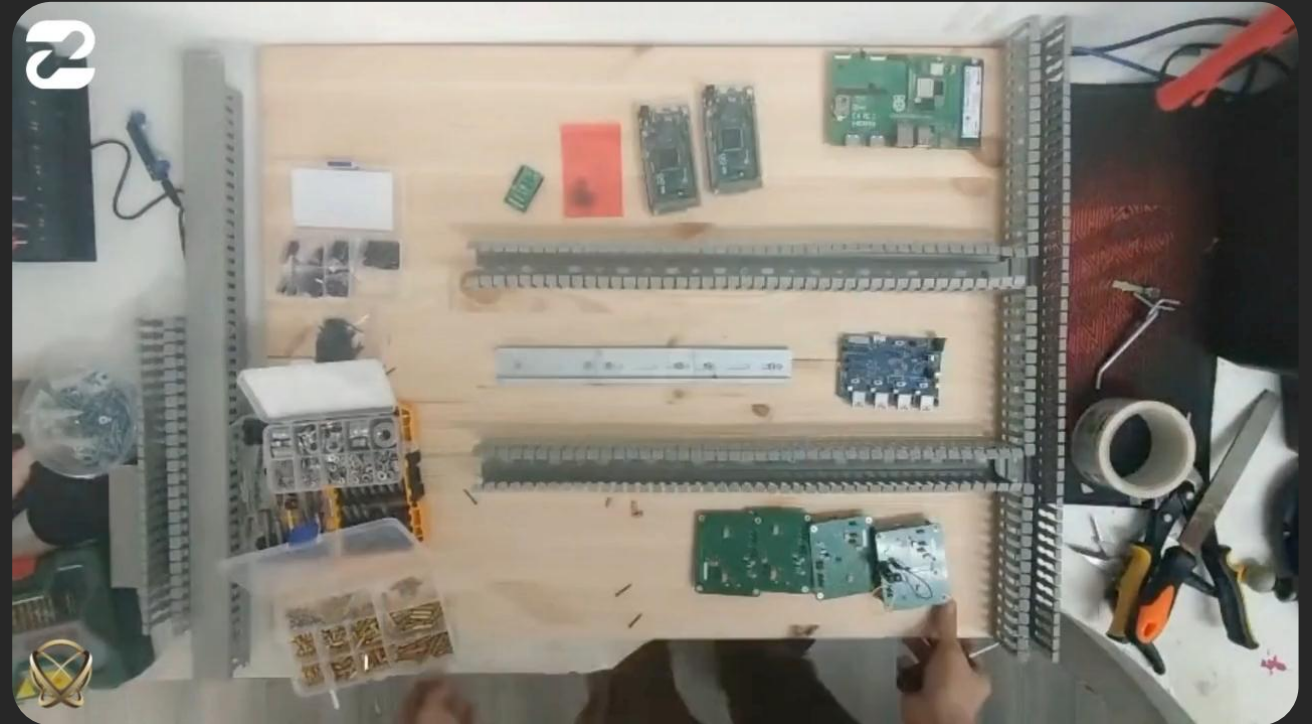



Future



MID-2026:
GROUND SYSTEM
OPERATIONAL



2027: TEST
FLIGHTS &
FACTORY
STABILIZATION



2028: FACTORY
OPERATIONAL



Questions?



Almog Zeron

Phone:

+972-52-8287698

E-mail:

Almog@zeron.tech